

1W, Fixed input voltage , isolated & unregulated
dual/single output

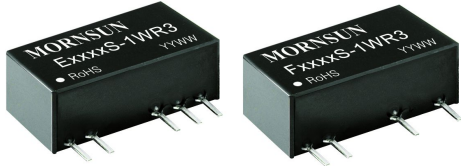

UL® CE Patent Protection RoHS

FEATURES

- Continuous short-circuit protection
- No-load input current as low as 5mA
- Operating temperature range: -40°C to +105°C
- High efficiency up to 85%
- Isolation voltage: 3K VDC
- International standard pin-out
- SIP package
- Meets UL62368, EN62368 standards(Pending)

E05_S-1WR3 & F05_S-1WR3 series are specially designed for applications where an isolated (two isolated) voltage is required in a distributed power supply system. They are suitable for: pure digital circuits, low frequency analog circuits, relay-driven circuits and data switching circuits.

Selection Guide

Certification	Part No.	Input Voltage (VDC)	Output		Efficiency (%Min./Typ.) @ Full Load	Max. Capacitive Load* (µF)
		Nominal (Range)	Output Voltage (VDC)	Output Current (mA) (Max./Min.)		
UL/CE (Pending)	E0505S-1WR3	5 (4.5-5.5)	±5	±100/±10	78/82	1200
	E0509S-1WR3		±9	±56/±6	79/83	470
	E0512S-1WR3		±12	±42/±5	79/83	220
	E0515S-1WR3		±15	±34/±4	79/83	
	F0503S-1WR3		3.3	303/30	70/74	2400
	F0505S-1WR3		5	200/20	78/82	
	F0509S-1WR3		9	111/12	79/83	1000
	F0512S-1WR3		12	84/9	79/83	560
	F0515S-1WR3		15	67/7	79/83	
	F0524S-1WR3		24	42/4	81/85	220

Note: *The capacitive loads of positive and negative outputs are identical.

Input Specifications

Item	Operating Conditions	Min.	Typ.	Max.	Unit
Input Current (full load / no-load)	3.3VDC/5VDC output	--	270/5	286/10	mA
	9VDC/12VDC output	--	241/12	254/20	
	15VDC/24VDC output	--	241/18	254/30	
Reflected Ripple Current*		--	15	--	
Surge Voltage (1sec. max.)	5 VDC input	-0.7	--	9	VDC
Input Filter			Capacitor filter		
Hot Plug			Unavailable		

Note: * Reflected ripple current testing method please see DC-DC Converter Application Notes for specific operation.

Output Specifications

Item	Operating Conditions	Min.	Typ.	Max.	Unit	
Output Voltage Accuracy		See tolerance envelope curve(Fig. 1)				
Line Regulation	Input voltage change: ±1%	3.3 VDC output	--	--	1.5	%/%
		Other output	--	--	1.2	
Load Regulation	10%-100% load	3.3VDC output	--	15	20	%
		5VDC output	--	10	15	
		9VDC output	--	8	10	
		12VDC output	--	7	10	
		15VDC output	--	6	10	
		24VDC output	--	5	10	

Ripple & Noise*	20MHz bandwidth	Other output	--	30	75	mVp-p
		24VDC output	--	50	100	
Temperature Drift Coefficient	100% load		--	±0.02	--	%/°C
Short Circuit Protection			Continuous, self-recovery			

Note: *Ripple and noise tested with "parallel cable" method, please see *DC-DC Converter Application Notes* for specific operation methods.

General Specifications

Item	Operating Conditions	Min.	Typ.	Max.	Unit	
Insulation Voltage	Input-output, with the test time of 1 minute and the leak current lower than 1mA	3000	--	--	VDC	
Insulation Resistance	Input-output, isolation voltage 500VDC	1000	--	--	MΩ	
Isolation Capacitance	Input-output, 100KHz/0.1V	--	20	--	pF	
Operating Temperature	Derating if the temperature ≥85°C (see Fig. 2)	-40	--	105	°C	
Storage Temperature		-55	--	125		
Casing Temperature Rise	Ta=25°C					
			3.3VDC output	--	25	--
			Others	--	15	--
Pin Welding Resistance Temperature	Welding spot is 1.5mm away from the casing, 10 seconds	--	--	300		
Storage Humidity	Non-condensing	--	--	95	%RH	
Switching Frequency	100% load, nominal input voltage	--	270	--	KHz	
MTBF	MIL-HDBK-217F@25°C	3500	--	--	K hours	

Physical Specifications

Casing Material	Black flame-retardant and heat-resistant plastic (UL94 V-0)
Package Dimensions	19.65*6.00*10.16mm
Weight	2.1g(Typ.)
Cooling Method	Free air convection

EMC Specifications

EMI	CE	CISPR32/EN55032 CLASS B (see Fig. 4 for recommended circuit)
	RE	CISPR32/EN55032 CLASS B (see Fig. 4 for recommended circuit)
EMS	ESD	IEC/EN61000-4-2 Air ±8kV , Contact ±4kV perf. Criteria B

Product Characteristic Curve

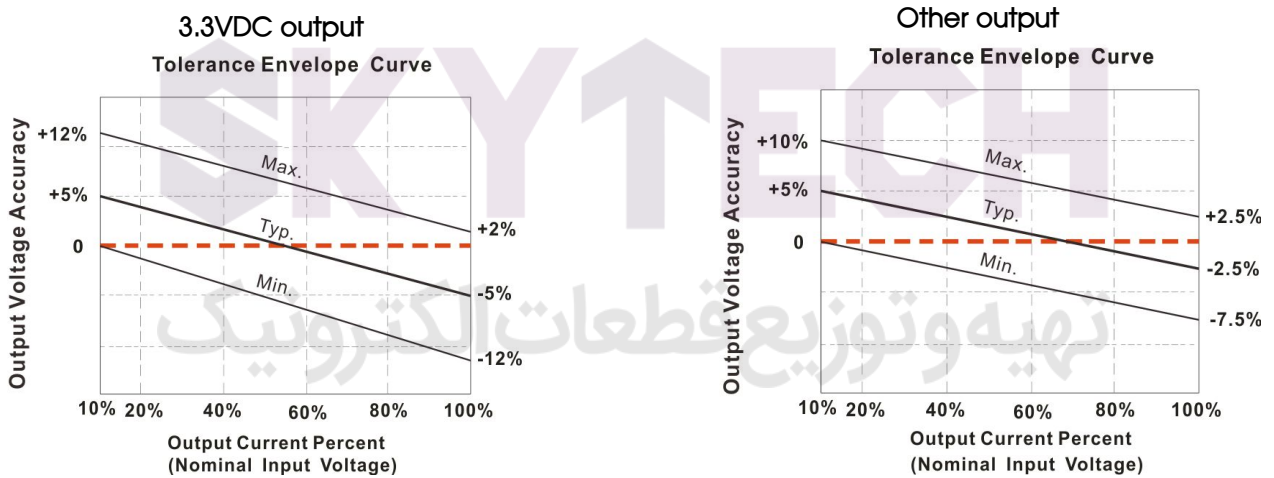

Fig. 1

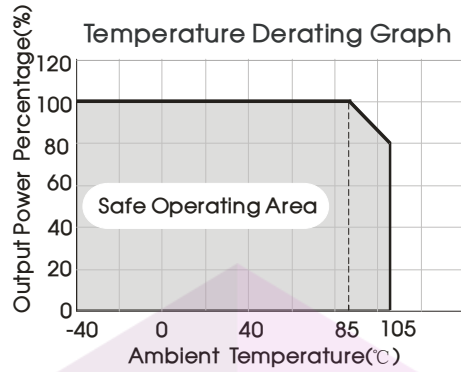
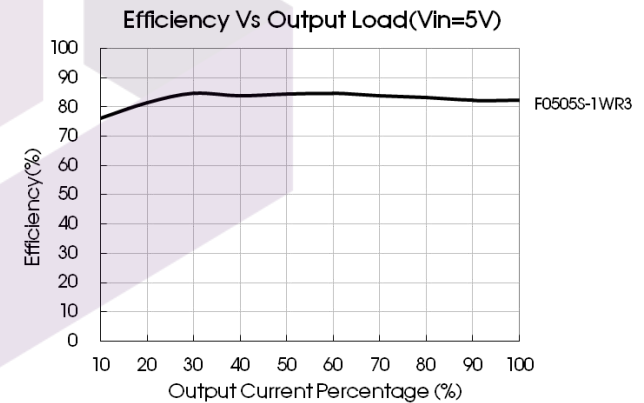
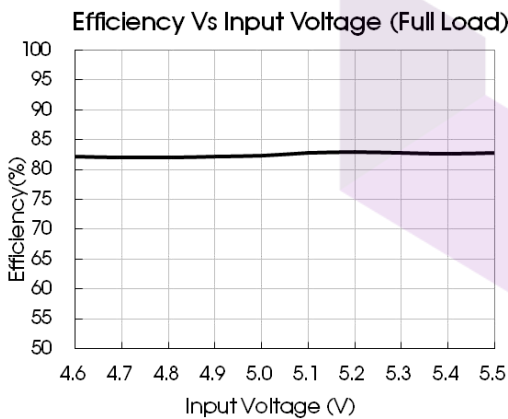
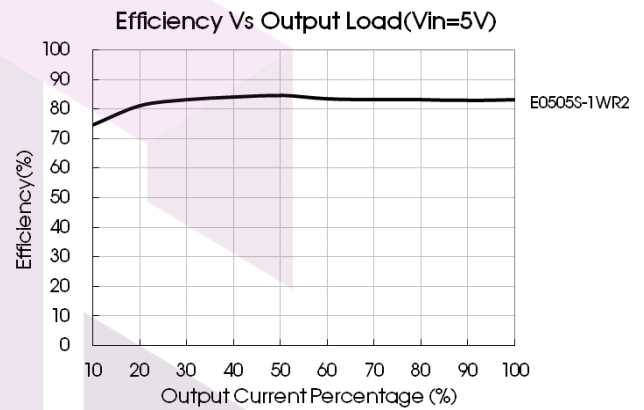
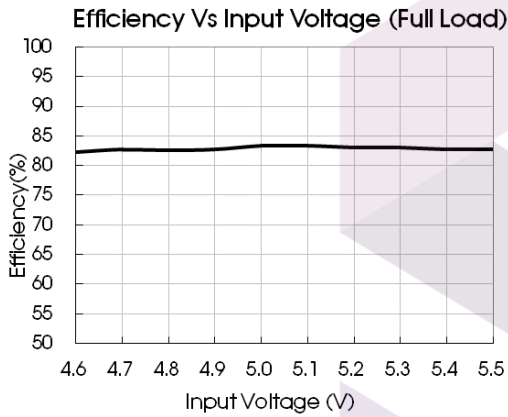

Fig. 2



Design Reference

1. Typical application

If it is required to further reduce input and output ripple, a filter capacitor can be connected to the input and output terminals, see Fig.3. Moreover, choosing suitable filter capacitor is very important, start-up problems may be caused by too large capacitance. To ensure the modules running well, the recommended capacitive load values as shown in Table 1.

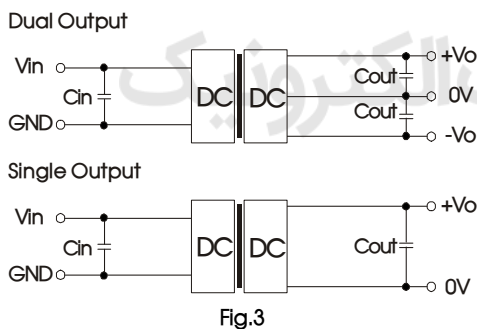

Recommended capacitive load value table (Table 1)

Vin (VDC)	Cin (μF)	Single output (VDC)	Cout (μF)	Dual output (VDC)	Cout (μF)
5	4.7	3.3/5	10	±5	4.7
--	--	9/12	2.2	±9/±12	1
--	--	15/24	1	±15	0.47

2. EMC solution-recommended circuit

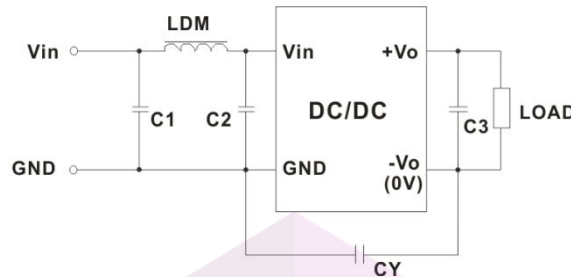

Fig. 4

EMC recommended circuit value table (Table 2)

Input voltage 5VDC	Output voltage (VDC)	3.3/5/9		12/15/24		
		EMI	C1/C2	4.7μF /25V		4.7μF /25V
		CY	--		1nF/4KVDC VISHAY HGZ102MBP TDK CD45-E2GA102M-GKA	
		C3	Refer to the Cout in table 1			
		LDM	6.8μH		6.8μH	

Note: In the case of actual use, the requirements for EMI are high, it is subject to CY (CY:1nF/4KV).

3. For more information please find the application notes on www.mornsun-power.com

Dimensions and Recommended Layout

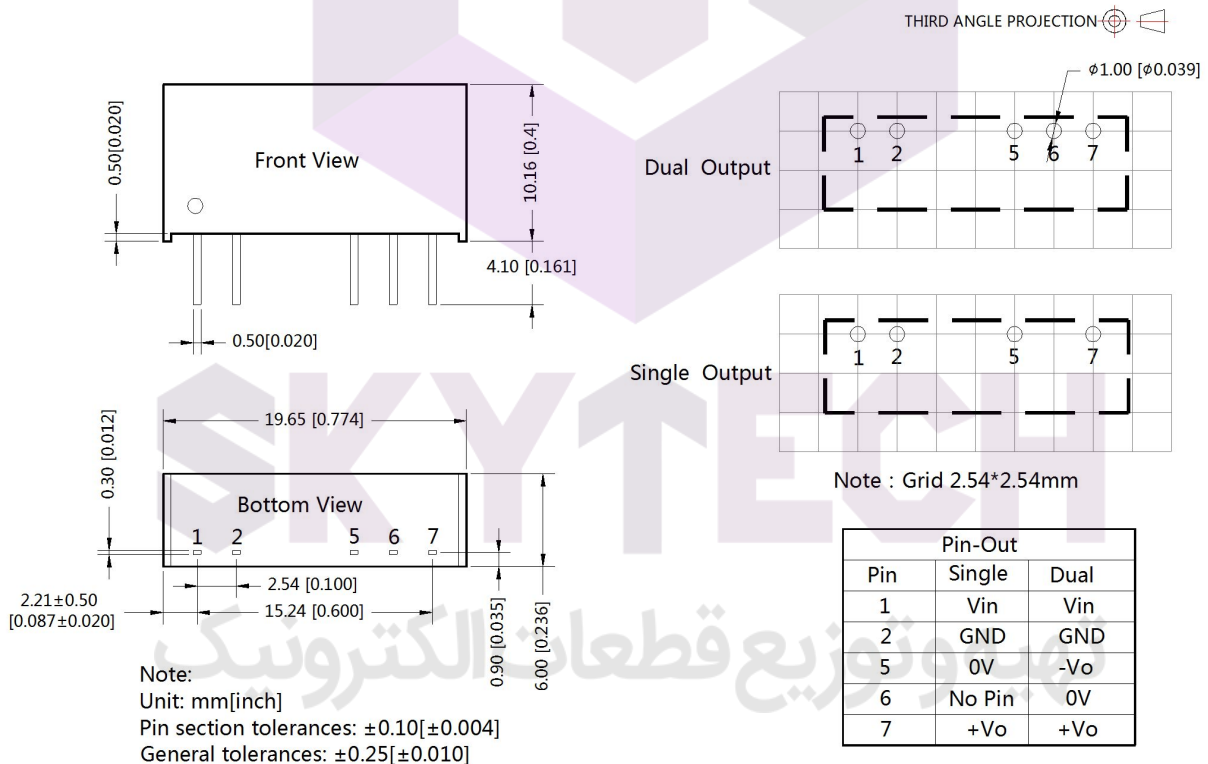



Notes:

1. Packing information please refer to Product Packing Information which can be downloaded from www.mornsun-power.com. Packing bag number: 58200001;
2. If the product is not operated within the required load range, the product performance cannot be guaranteed to comply with all parameters in the datasheet;
3. The maximum capacitive load offered were tested at input voltage range and full load;
4. Unless otherwise specified, parameters in this datasheet were measured under the conditions of $T_a=25^{\circ}\text{C}$, humidity<75%RH with nominal input voltage and rated output load;
5. All index testing methods in this datasheet are based on our Company's corporate standards;
6. We can provide product customization service, please contact our technicians directly for specific information;
7. Products are related to laws and regulations: see "Features" and "EMC";
8. Our products shall be classified according to ISO14001 and related environmental laws and regulations, and shall be handled by qualified units.

MORNSUN Guangzhou Science & Technology Co., Ltd.

Address: No. 5, Kehui St. 1, Kehui Development Center, Science Ave., Guangzhou Science City, Luogang District, Guangzhou, P. R. China
Tel: 86-20-38601850-8801 Fax: 86-20-38601272 E-mail: info@mornsun.cn